

LIL FELLA MID SIZE JUICE

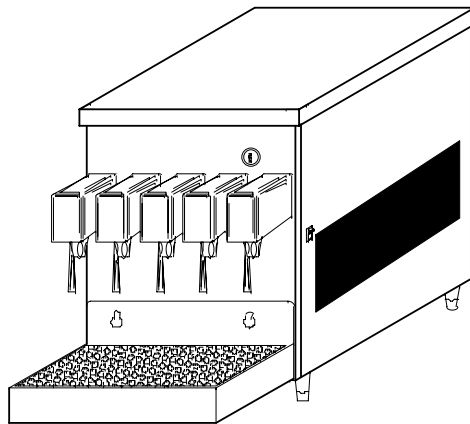

LF-MS-J

INSTALLATION AND SERVICE MANUAL

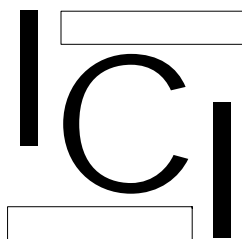

INTERNATIONAL CARBONIC INC.
16630 Koala Rd.
Adelanto, CA 92301
800 854-1177

IMPORTANT: This manual is a guide for installing, operating, servicing and maintaining this equipment. Refer to Table of Contents for page location of detailed information to answer questions that arise during installation, operating, service and maintenance, or installation of this equipment.

TABLE OF CONTENTS

	Page
PREFACE	1
CHAPTER I GENERAL DESCRIPTION	1-1
SYSTEM DESCRIPTION.....	1-1
DESIGN DATA	1-1
EXPLODED VIEW	1-2
EXPLODED VIEW PARTS DESCRIPTION	1-3
110 VOLT ELECTRICAL SCHEMATIC	1-5
24 VOLT ELECTRICAL SCHEMATIC	1-6
THEORY OF OPERATION.....	1-7
CHAPTER II INSTALLATION	2-1
UNPACKING AND INSPECTION.....	2-1
SELECTING LOCATION	2-1
LOCATION RECOMMENDATIONS FOR LF-MS-J JUICE	2-1
INSTALLATION	2-2
INSTALL HIGH PRESSURE C02 REGULATOR, C02 CYLINDER, AND LINES	2-2
INSTALL LOW PRESSURE REGULATOR.....	2-3
INSTALL WATER FILTER ASSY	2-3
INSTALL DRAIN LINE	2-4
INSTALL B.I.B. OR SYRUP TANKS AND ACCESSORIES.....	2-4
CONNECTING WATER INLET	2-4
ELECTRICAL REQUIREMENTS.....	2-4
CHAPTER III PREPARATION.....	3-1
PREPARING SYSTEM FOR OPERATION.....	3-1
PREPARING AND STARTING REFRIGERATION UNIT.....	3-1
PURGE DISPENSING VALVE	3-1
ACTIVATE HIGH PRESSURE C02 SYSTEM.....	3-1
ACTIVATE LOW PRESSURE C02 GAS.....	3-1
ADJUST WATER FLOW RATE	3-2
ADJUST WATER-TO-SYRUP "RATIO".....	3-2
ADJUST SIZE OF DRINK DISPENSED.....	3-2
CHAPTER IV OPERATORS INSTRUCTIONS	4-1
DAILY PRE-OPERATION CHECK.....	4-1
REPLENISHING C02 SUPPLY	4-1
COOLING UNIT MAINTENANCE.....	4-1
CHECKING WATER BATH	4-1
CHANGING WATER BATH.....	4-1
ADJUSTMENTS	4-1
TESTING FOR LEAKS	4-2
CHAPTER V SERVICE AND MAINTENANCE	5-1
PERIODIC INSPECTION AND CLEANING	5-1
CLEANING CONDENSER COIL	5-1
CHECKING WATER BATH	5-2
CHANGING WATER BATH.....	5-2
HIGH PRESSURE C02 REGULATOR.....	5-2

	Page
LOW PRESSURE CO2 REGULATOR	5-3
REPLENISHING CO2 SUPPLY	5-3
CLEANING AND SANITIZING	5-3
BRIX INSTRUCTIONS.....	5-5
PROPER BRIXING PROCEDURES	5-6
CHAPTER VI TROUBLESHOOTING	6-1
FROZEN WATER BATH.....	6-1
COOLING OR CONDENSING UNIT NOT OPERATIONAL.....	6-1
COMPRESSOR DOES NOT OPERATE.....	6-2
COMPRESSOR WORKS CONTINUOUSLY BUT DOES NOT FORM SUFFICIENT ICE BANK	6-2
COMPRESSOR WILL NOT STOP AFTER FORMING ICE BANK	6-2
CONDENSER FAN MOTOR NOT OPERATING	6-2
DISPENSING VALVES	
WATER OR SYRUP LEAKING FROM NOZZLE AFTER ACTUATION.....	6-3
NO WATER, NO SYRUP BEING DISPENSED FROM VALVE	6-3
NO SYRUP BEING DISPENSED	6-4
NO WATER BEING DISPENSED	6-4
WATER TO SYRUP RATIO TO LOW OR TO HIGH.....	6-4
ADJUSTMENT OF SYRUP METERING PIN DOES NOT PRODUCE DESIRED WATER TO SYRUP RATIO	6-4
NOTE PAGE	6-5

LIST OF FIGURES

Fig.	Title	
1-1	EXPLODED VIEW	1-2
1-2	PARTS BREAKDOWN.....	1-3
1-3	S-1309 ELECTRICAL SCHEMATIC	1-4
1-4	VALVE SCHEMATIC	1-5
2-1	POSSIBLE INSTALLATION.....	2-2
2-2	HIGH PRESSURE REGULATOR.....	2-3
2-3	LOW PRESSURE REGULATOR.....	2-3
2-4	SUGGESTED WATER FLOW INSTALLATION	2-3
5-1	BRIX ILLUSTRATION VALVE TOP VIEW AND BRIX CUP.....	5-5
5-2	BRIX ILLUSTRATION	5-6

PREFACE

INTERNATIONAL CARBONIC INC. has enjoyed over 53 years of manufacturing excellence in the field of carbonation and in the beverage related industry. We have been located in the Southern California area since 1952 and have a long and proud history with quality as our standard and innovation as our goal. Originally started just after World War II in Canfield Ohio as Carbonic Dispensers we enjoyed patents on the first Sodajet type carbonator. This method of carbonation instantaneously carbonated the water to 100% saturation. We developed the first patented dispensing valve to dispense bulk beverage with carbonation equal to or in excess of bottled beverages. A valve with three flavors and soda was another first. We were the first to incorporate the total post-mix package, i.e., carbonation, refrigeration & the ability to dispense from one self contained unit. We have pioneered many such firsts and will continue to develop advance systems for the future, such as electronic interrogatable portion controls to electronic liquid level controls.

We hope you enjoy this product that has been produced to give many years of trouble free service. We thank you for your purchase and hope we may serve you in the future.

1
LF-MS-J
CHAPTER I

GENERAL DESCRIPTION

This chapter gives the description, theory of operation, and design data for the LIL FELLA MID SIZE JUICE, (LF-MS-J), and related components.

SYSTEM DESCRIPTION

The LF-MS-J is a complete self-contained Juice unit which when combined with related components, will produce a variety of cooled non-carbonated beverages.

The LF-MS-J consists of a condensing unit, a water reservoir, water-cooling coil, an agitator pump, and optional syrup cooling coil(s) and dispensing valve(s).

For proper function the LF-MS-J must have a water supply, and electrical supply and drainage. The LF-MS-J is designed with a unique lift off drain pan that can be emptied at any convenient drain outlet. Other items that will be required if used in B.I.B., (Bag in Box), or transfer tank, (FIGAL), installations will be High-pressure regulator, Low-pressure regulator, connecting lines, quick couplers, or disconnects and C02.

WARNING: Before shipping or relocating a LF-MS-J into a freezing ambient environment empty plain water. Syrup systems should be flushed, ice bank melted, and water drained from water bath. A freezing ambient environment will cause existing water in unit to freeze possibly resulting in damage to water coil, syrup coils, water bath, valve(s), etc.

Water Filter Recommended (Optional) See Manufacturer Specifications for Operating Conditions

DESIGN DATA

LF-MS-J

Overall dimensions:

Height	24 1/2
Width	12
Depth	18 3/4

Weights

Shipping	115 pounds
Dry weight	97 pounds
Operational Weight	130 pounds

Capacities:

Unit water bath	5.0 gallons
Refrigerant requirement (R-134a)	5.8 ounces
.....	165 grams

Ambient operating temperature 40 F to 100 F

Electrical Requirements:

The cooling unit requires a 115 VAC, single phase, 60-Hertz power circuit.

Circuit Ampacity	3.4 Amps
Condensing Unit	2.1 Amps
Agitator8 Amps

REFRIGERATION 1/5 H.P. capillary air-cooled.

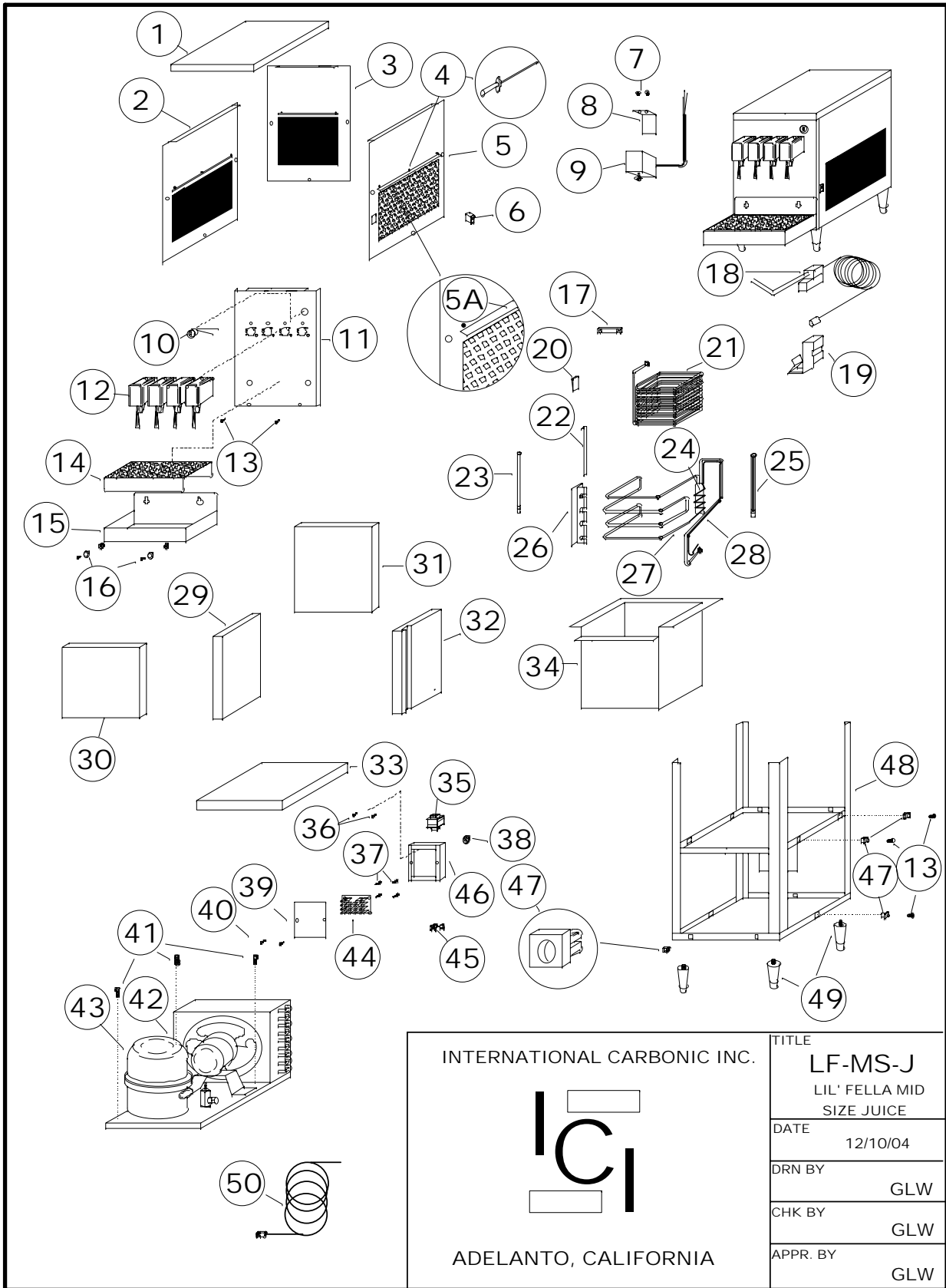

INTERNATIONAL CARBONIC INC.

ICI

ADELANTO, CALIFORNIA

TITLE	LF-MS-J LIL' FELLA MID SIZE JUICE
DATE	12/10/04
DRN BY	GLW
CHK BY	GLW
APPR. BY	GLW

FIGURE 1-1
1-2

LF-MS-J

SYM	QTY	PART NO.	DESCRIPTION
1	1	S1340	LID W/INSULATION
2	1	S1338	SERVICE PANEL, LEFT SIDE
2A**	1	S1338-A	SERVICE PANEL AWNING, LEFT SIDE
3	1	S1337	SERVICE PANEL, REAR
3A**	1	S1337-A	SERVICE PANEL AWNING, REAR
4	8	A0051-A	RIVETS, BLACK
5	1	S1339	SERVICE PANEL, RIGHT SIDE
5A	1	S1339-A	SERVICE PANEL AWNING, RIGHT SIDE
6	1	S0783	UNIT ON/OFF SWITCH
7	2	F0004	SCREW, #8 X 5/16 T.H., S.S. TYPE F
8	1	S1341-LG	AGITATOR PUMP BRACKET
9	1	S0835	AGITATOR PUMP
10	1	S1330	SWITCH W/KEYS
11	1	S1336	VALVE MOUNTING PLATE
12	4	PFC-II	VALVE
13	11	A0014	SCREW, #10 X 1/2", TH SS
14	1	S1149-A	CUP REST
15	1	S1149	DRAIN PAN
16	1	S0743	DRAIN PAN MTG HARDWARE
17	3	S-1324	POSITIONING BAR
18	1	S0513-A	ICE BANK CONTROL
19	1	S1304-U	ICE BANK CONTROL BRACKET
20	5	S1323	EVAPORATOR WEDGE
21	1	S1334	WATER COIL, COPPER
22	5	S0661	EVAPORATOR COIL RETAINER
23	1	S0657	STANDPIPE, 7 3/4", WHITE
24	1	S0509	ACCUMULATOR
25	1	S0658	OVERFLOW, 8", GRAY

FIGURE 1-2

1-3

LF-MS-J Cont.

SYM	QTY	PART NO.	DESCRIPTION
26	5	S0662	EVAPORATOR SUPPORT BRACKET
27	1	S1333	EVAPORATOR COIL ASSEMBLY
28	1	Z0009	CAP TUBE 12' .042
29	1	''''	INSULATION, LEFT SIDE
30	1	''''	INSULATION, FRONT
31	1	''''	INSULATION, REAR
32	1	''''	INSULATION, RIGHT SIDE
33	1	''''	INSULATION, BOTTOM
34	1	S1332	BUCKET ASSY., WITH INSULATION
35	1	E0276	TRANSFORMER
36	2	A0049	SCREW, 8-32 X 3/8 PHILL. PH
37	4	S1335	TERMINAL BOARD SPACER, NYLON
38	4	S0046	BUSHING
39	1	S1310	TERMINAL BOX COVER
40	2	A0020	SCREW, 8-32 X 3/8 TH SS
41	3	A0046	SCREW, 5/16-18 X 3/4 WHIZ LOCK
42	1	AEA1360YXAXA	CONDENSING UNIT, 1/5 H.P.
43	1	AEA1360YXA	COMPRESSOR ONLY, 1/5 H.P.
44	1	S1309	TERMINAL BOARD
45	1	E0664	STRAIN RELIEF
46	1	S1308	TERMINAL BOX WITH COVER
47	11	S1325	SQUARE GROMMET NUT
48	1	S-1331	FRAME COMPLETE
49	1 SET	S-765	LEGS, 4ea
50	1	E-141-12	POWER CORD

FIGURE 1-2 Cont.
1-4

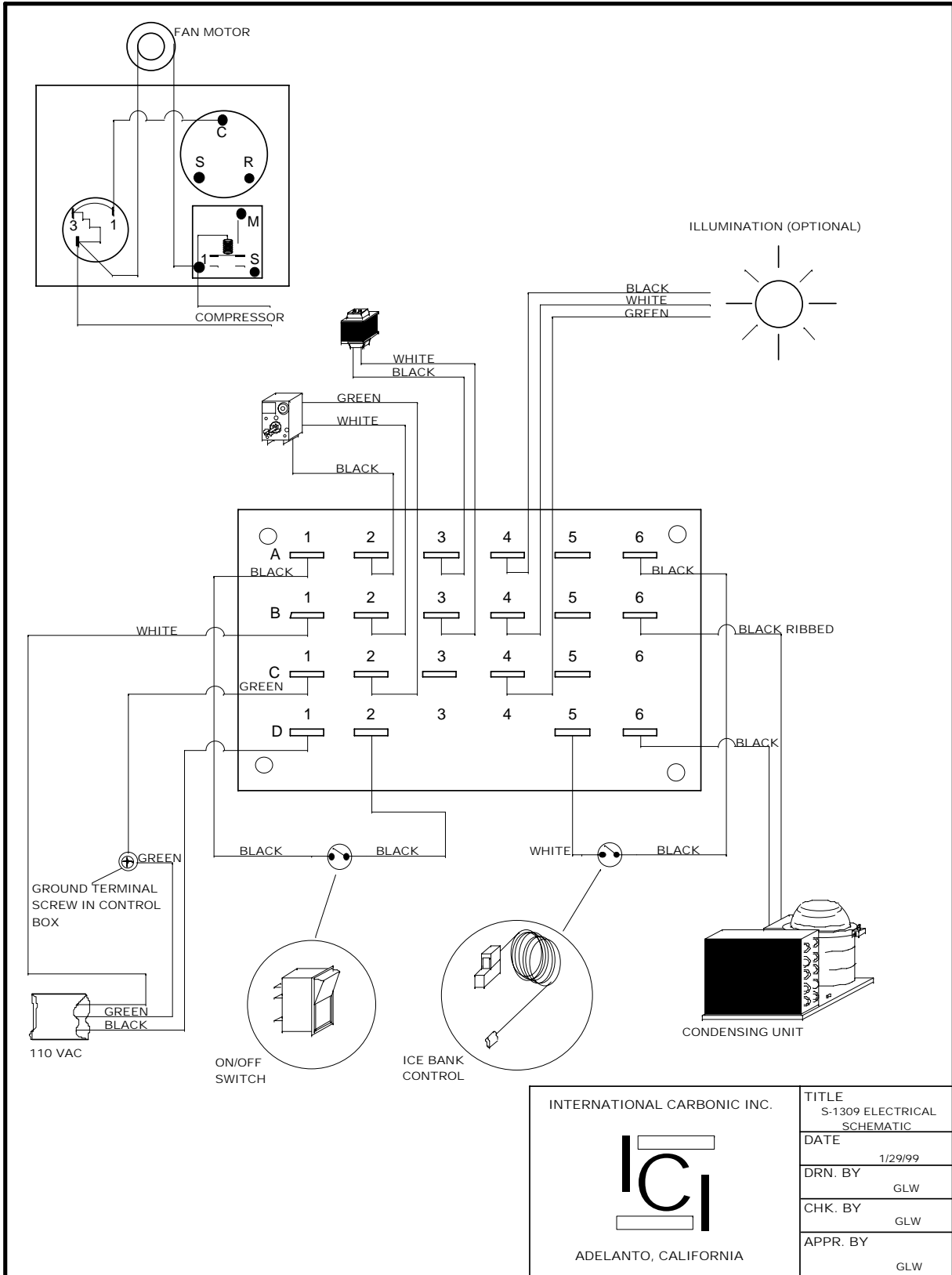

INTERNATIONAL CARBONIC INC.  ADELANTO, CALIFORNIA	TITLE
	S-1309 ELECTRICAL SCHEMATIC
	DATE
	1/29/99
	DRN. BY
	GLW
CHK. BY	
GLW	
APPR. BY	
GLW	

FIGURE 1-3
1-5

VALVE SCHEMATIC

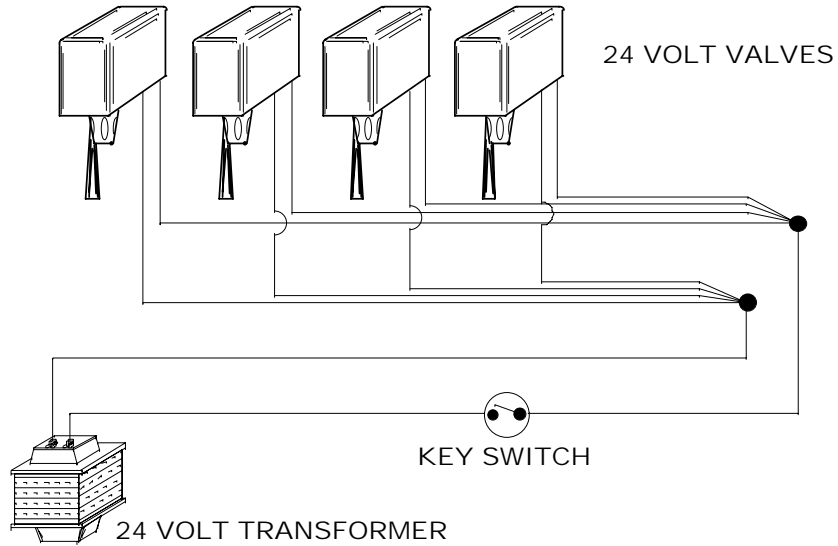
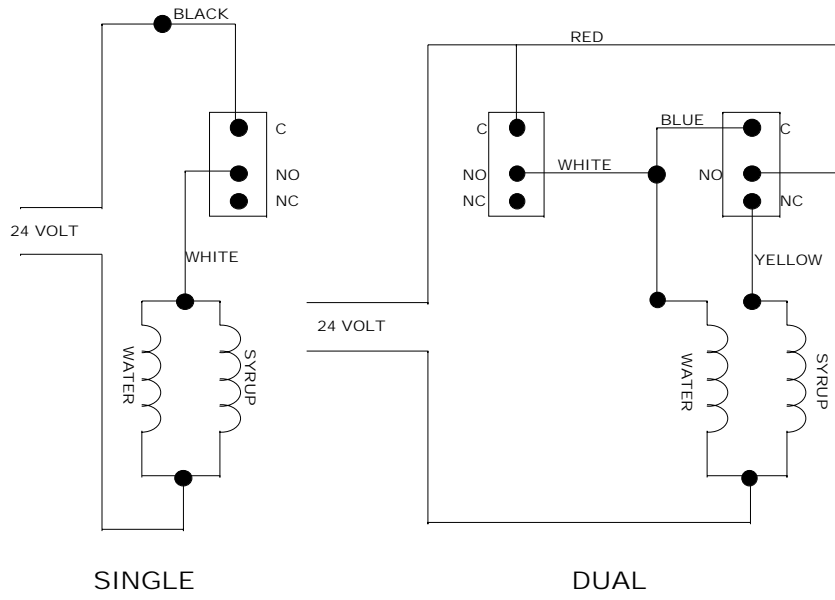

ELECTRICAL SCHEMATIC 24 VOLT

THEORY OF OPERATION

The LF-MS-J was designed to manufacture and dispense non-carbonated beverages much like your local bottling plant that cans or bottles your favorite non-carbonated drink.

Initially water is chilled, to chill the water, the water is routed through a water coil that is submerged in an ice-cold water bath. The temperature of the incoming water is at ambient temperature as it enters the water coil. As the incoming water passes through the water coil the heat is removed from the water in the water coil and chilled to a temperature acceptable for a quality drink. The water is now directed to a valve where the water and syrup are mixed at a valve in proper proportions to dispense a quality drink.

The water bath holds approximately 5 gallons of water. A certain amount of this water will be transformed into ice, approximately 17 pounds. This water reserve and ice bank will act as a reservoir for refrigeration. This reserve is utilized during peak periods when the BTU output of the compressor is not sufficient to meet the demand of the draw.

The following will give a general overview of the flow of individual circuits and a clearer understanding of LF-MS-J unit.

Carbon dioxide gas (CO₂) passes from a CO₂ cylinder through high-pressure regulator (S-101). The high-pressure regulator regulates the CO₂ gas feeding the LF-MS-J's low-pressure system and should be set at 70-75 PSI. The gas, after leaving the high-pressure regulator, is routed through flexible tubing to a low-pressure regulator. The CO₂ is routed through low-pressure regulator to be regulated to a pressures suitable for the syrup concentrate being dispensed. The low-pressure regulator may be set at many different settings but primarily the settings are directed towards B.I.B. or transfer tank type installations. The average settings may vary from 10 to 60 PSI. This of course will be influenced by length of run, ambient temperature and baume of product. Typically B.I.B. installations are set at an average of 40 PSI and transfer tank installations are set at an average of 30 PSI.

As discussed earlier plain water enters the LF-MS-J through the incoming water line. This water proceeds through the water coil where it is chilled prior to going directly to a valve. When the chilled water reaches the valve it is mixed at a ratio, (adjustable), with the syrup concentrate coming from the B.I.B. or Transfer Tank.

The water source should be regulated, this is normally performed by the use of an in line water regulator. If the water is not regulated and the water pressure can vary. This variance of water pressure can affect our dispensed product.

1-7
 CHAPTER II
INSTALLATION
 LF-MS-J

This chapter covers unpacking and inspection, selecting location, installing LIL FELLA MID SIZE JUICE, LF-MS-J and related components, and electrical requirements.

UNPACKING AND INSPECTION

Upon receiving unit, immediately remove LF-MS-J from shipping carton and inspect for shipping damage.

NOTE: Before leaving the factory the LIL FELLA MID SIZE JUICE was carefully inspected and the carrier has accepted and signed for it. Any damage or irregularities should be noted at the time of delivery and immediately reported to delivering carrier. Request a written inspection report from claims inspector to substantiate any necessary claim. File claim with delivering agency, not **International Carbonic Inc!**

SELECTING LOCATION

IMPORTANT: Ambient temperature for cooling unit should not exceed 100 degrees "F". Operation of cooling unit in ambient above 100 degrees "F" can and will contribute to early failure of condensing unit and poor quality of finished product.

LOCATION RECOMMENDATIONS FOR LIL FELLA MID SIZE JUICE, LF-MS-J

1. Position unit as close as possible to proper electrical source, 115V 60Hz.
2. Position unit with a minimum of 2" space between bulkhead and cabinet for sufficient space for ventilation. Allow enough space between ceiling and unit for lid removal.
3. Position unit as close as possible to floor drain.

TABLE 2-1

LOOSE - SHIPPED PARTS

Item No.	Part No.	Name	Qty
1		Installation/Service Manual	1
2	S-1149	Drain pan	1
3	----	Product Decals	1 per flavor
4*	S-101	High-pressure C02 Regulator	1
5*	S-221	Low-pressure C02 Regulator	1
6*		Water filter	1
7*	S-105	6' Gas Line (Inner Braid)	1
8*	S-208A	Water Pressure Regulator	1
*	Optional		

LOCATION RECOMMENDATIONS FOR LF-MS-J

1. Position unit as close as possible to proper electrical source, 120V 60HZ.
2. Position unit with a minimum of 2" space between bulkhead and cabinet for sufficient ventilation. Allow enough space between ceiling and unit for cover removal.
3. Position unit as close as possible to water source. Half-inch gate valve recommended for water connection.
4. Enough space must be allowed to install C02 cylinder, syrup containers, racks, pumps, water filter, etc.

5. Position unit as close as possible to floor drain.

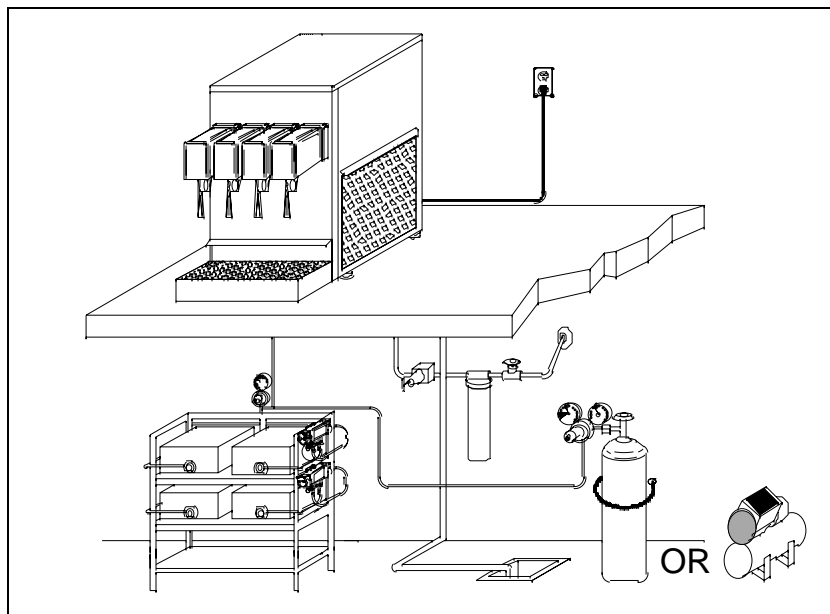

FIGURE 2 SAMPLE OF POSSIBLE INSTALLATION.

INSTALLATION

1. Make all connections:
2. Place LF-MS-J in position. Make sure sufficient space between bulkheads, walls and overheads is available for proper ambient temperature and air circulation around LF-MS-J.

INSTALL HIGH-PRESSURE C02 REGULATOR, C02 CYLINDER AND LINES

1. Install high-pressure C02 regulator, (S-101) on C02 cylinder using a new seal gasket.

MAKE SURE NEW WASHER IS INSIDE REGULATOR ASSEMBLIES COUPLING NUT BEFORE CONNECTING TO CYLINDER.

WARNING-: To avoid personal injury and/or property damage, always secure C02 cylinder with safety chain to prevent cylinder from falling. It is recommended that the C02 cylinder be installed away from heavily traveled areas such as doors, passageways, corridors, etc.

2. Connect 1/4" inner braided plastic tubing from outlet of high-pressure C02 regulator, (S-101), on C02 cylinder to Tee connection at low-pressure regulator, (S-221), using prefabricated gas charging line, (S-105).

INSTALL LOW-PRESSURE REGULATOR AND LINES (OPTIONAL)

1. Install low-pressure C02 regulator on the wall or another supporting structure in general vicinity of cooling unit, C02 cylinder, B.I.B. rack or syrup tanks.
2. Connect 1/4" inner braided plastic tubing from outlets of low-pressure C02 regulator, (S-221), to inlets of B.I.B. pump or syrup tanks.

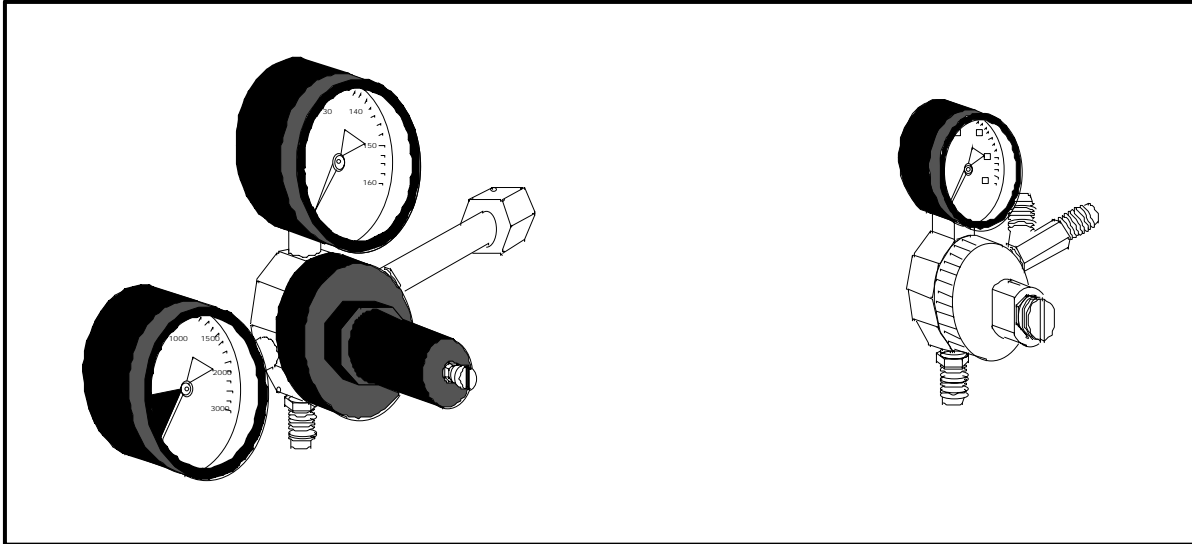

FIGURE 2-2
HIGH PRESSURE REGULATOR
S-101

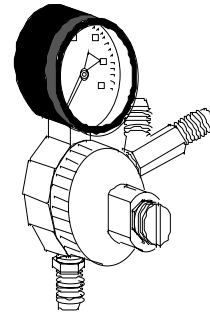

FIGURE 2-3
LOW PRESSURE REGULATOR
S-221

INSTALL WATER FILTER ASSY. (OPTIONAL)

1. Install water filter assembly on wall or other supporting structure.
2. Connect water filter assembly to inlet of valve on water supply line using minimum 3/8" I.D. water line.
3. Connect water filter assembly outlet to LF-MS-J plain water inlet fitting using minimum 3/8" I.D. water line. See CONNECTING WATER INLET.

When a water filter is used, it is important that it has a minimum 100 gallons per hour capacity and should be thoroughly flushed before it is connected to the water inlet connection.

INSTALL WATER PRESSURE REGULATOR (OPTIONAL)

If water pressure varies, a water pressure regulator or water pressure-reducing valve should be installed in the water supply line. The water regulator must have an orifice of at least 3/16" so as not to restrict the water flow through the valve. Valves that are built with 1/2" pipe thread connection usually have a sufficient orifice opening.

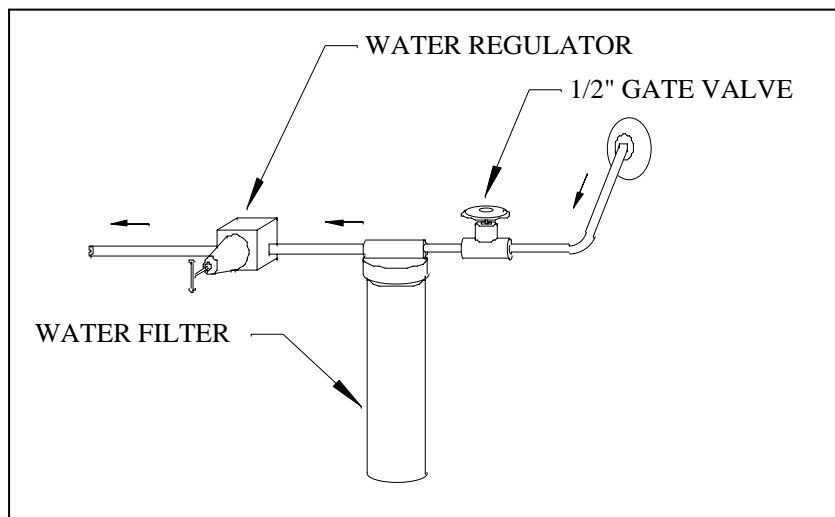

FIGURE 2-4. SUGGESTED WATER FLOW INSTALLATION
2-3

INSTALL DRAIN LINE

1. Connect drain line on LF-MS-J unit with drain using 1/2" I.D. clear plastic tubing to nearest outlet.
2. Do not reduce drain connection from cabinet outlet.
3. Be sure all connections are watertight.

INSTALL B.I.B. OR SYRUP TANKS AND ACCESSORIES (OPTIONAL)

1. Place B.I.B. or syrup tanks as close as possible to LF-MS-J unit, preferably no farther than 5 feet.
2. Lay out syrup lines from unit to syrup pumps or tanks.
3. Connect lines from low-pressure regulator for B.I.B. or transfer tank installations.
4. Connect line from low-pressure regulator to Q.C.D. for B.I.B. or install quick-disconnect for transfer tank type installations.
5. Install incoming syrup line to unit on Q.C.D. for B.I.B.
6. Install quick-disconnect on incoming line to accommodate transfer tank installs.
7. Activate Q.C.D. or install quick disconnects to transfer tanks.
8. Check all connections for leaks, (see Chapter IV).

CONNECTING WATER INLET

WATER PIPE CONNECTIONS AND FIXTURES DIRECTLY CONNECTED TO POTABLE WATER SUPPLY SHALL BE SIZED, INSTALLED AND MAINTAINED ACCORDING TO FEDERAL, STATE, AND LOCAL LAWS.

The water connection on the LF-MS-J is made to a flexible water line by means of a 3/8", male flare.

After all primary water lines are made up, but prior to connecting water supply to cabinet, be sure to thoroughly flush all incoming water lines to remove all scale and any impurities that may be in the lines. It is imperative that the fresh water-conduit have not less than 3/8" I.D. passageway for any distance greater than ten feet from the LF-MS-J. It can be reduced to 3/8" O.D. copper tubing and connected to the water inlet connection with-in ten feet of the LF-MS-J. All water inlet connections are clearly tagged.

ELECTRICAL REQUIREMENTS:

The LF-MS-J requires a 120 VAC, single phase, 60-Hertz power circuit, and must be wired in accordance with N.E.C. or local ordinance.

NOTE: Check CHAPTER I for running amperage and connect to appropriate electrical circuit.

2-4
CHAPTER III
LF-MS-J
PREPARATION

All steps in previous chapters should be understood and carried out before proceeding.

PREPARING SYSTEM FOR OPERATION

Be sure that electrical power is unplugged, valve on C02 cylinder is closed, valve on water supply line is closed.

PREPARING AND STARTING REFRIGERATION UNIT

1. LF-MS-J refrigeration is pre-set at factory and ready to operate.
2. Remove lid.
3. Fill water bath with clean water until water runs out of condensate drain outlet, (S-657), (approximately ½" from top of water bath).
4. Open water inlet supply line.
5. Plug LF-MS-J power cord into electrical receptacle box, turn power switch to the "ON" position. Make sure compressor, condenser fan motor, agitator motor start. The process of cooling the water bath will now commence. With ambient and water temperature of 75 degree "F" initial pull down or formation of complete ice bank will take approximately 3.5 hrs. When full ice bank has been formed, compressor and condenser fan motor will stop. Agitator will continue to operate, circulating water in water bath.

PURGE DISPENSING VALVES

Dispense water from dispensing valves until all air is purged from water lines.

ACTIVATE HIGH PRESSURE C02 SYSTEM

1. Open valve on the C02 cylinder. Be sure to open valve completely or until valve is back seated.
2. Turn high pressure C02 regulator screw clockwise until the pressure is 70 to 75 psi.
3. Check all connections on high pressure C02 system for leaks. Repair any leaks that are found.

ACTIVATE LOW PRESSURE C02 GAS AND SYRUP SYSTEMS (OPTIONAL)

1. Make sure high pressure C02 regulator pressure is 70 to 75 psi.
2. Make sure all B.I.B. racks or syrup tanks are full.
3. Make sure all Q.C.D.,s are in a operational position or gas and syrup quick disconnects are connected tightly with syrup tanks.
4. Turn low pressure C02 regulator screw clockwise until the pressure is approx. 40 psi for B.I.B. and approx. 30 psi for FIGAL.

NOTE: These pressures will vary depending on baume of product, type of pumps, etc.

5. Dispense syrup from dispensing valves until all air is purged from syrup lines and syrup is dispensed.

6. Check for syrup and gas leaks. Repair any leaks that may be found.

ADJUST WATER FLOW RATE

Adjust dispensing valves water flow rate as instructed in chapter IV, OPERATORS INSTRUCTIONS.

ADJUST WATER-TO-SYRUP "RATIO"

Adjust dispensing valves for Water-to-syrup "Ratio" of dispensed product as instructed in chapter IV, OPERATOR INSTRUCTIONS.

ADJUST SIZE OF DRINK DISPENSED (FOR PORTION CONTROL VALVES-PCT ONLY)

Adjust size of drink dispensed as instructed in chapter IV, OPERATOR INSTRUCTIONS.

3-2
CHAPTER IV
LF-MS-J
OPERATORS INSTRUCTIONS

This chapter covers operators' responsibilities for daily pre-operation check, adjustments, replenishing C02 and cleaning, and sanitizing.

DAILY PRE-OPERATION CHECK

1. Make sure high-pressure C02 regulator's pound per square inch indicator is not in shaded portion of dial. If so, C02 cylinder is almost empty and must be replaced.

NOTE: This reading should be carried out at normal room temperature.

2. Make sure B.I.B.'s or transfer tanks are full and ready to dispense.

REPLENISHING C02 SUPPLY

NOTE: When pound per square inch indicator of high pressure C02 regulator on C02 cylinder is in shaded portion of the dial, C02 cylinder is almost empty and should be changed.

C02 supply must be checked daily and if necessary, replenished as instructed (see CHAPTER II).

COOLING UNIT MAINTENANCE

NOTE: Air circulation through the condenser coil required to cool the condenser coil/compressor, is drawn in through grills on cooling unit, through condenser coil and is exhausted out grills on the other side of the unit. Restricting air circulation through the cooling unit will decrease its cooling capacity.

To avoid needless and sometimes costly repairs, it is imperative to keep condenser fins clean. This may be accomplished by one of three methods. One method is use of a condenser brush (a longhaired, soft bristle brush) to gently sweep fins of condenser clean. Second method is to use a strong vacuum. The third method is to use C02 or an air hose to blow out condenser. The latter method should only be attempted after normal business hours to avoid dust contamination.

CHECKING WATER BATH

Periodically check water level in water bath. If water level is low, water should be added as instructed for maximum product cooling. This dehydration will normally not occur in normal temperate climate zones. With normal humidity the opposite will occur therefore it is paramount that the condensate drain be installed.

CHANGING WATER BATH

Drain water bath a minimum of twice a year. This can be accomplished by locating the standpipe in the water bath area and removing by twisting and pulling up. Once water is drained, water bath, water coils, bath walls, etc. should be cleaned. Replace standpipe and refill with water. Fill water bath to top of standpipe, (S-657).

AJDJUSTMENTS

Periodically C02 regulators should be checked for proper pressure settings and if necessary, adjusted as instructed. These settings can be recorded in NOTE section of this manual.

TESTING FOR LEAKS

1. Completely back off adjusting screw on low pressure CO₂ regulator.
2. Close valve on top CO₂ cylinder.
3. Wait for 5 minutes or more. If pressure on high pressure gauge decreases excessively, there is leak in the gas circuit.
4. All connections including cylinder valve should be coated with a soap solution. If bubbles appear a leak is apparent.
5. Always be sure that the low pressure adjusting screw is completely backed off before testing high-side circuit for leaks. Otherwise, gas going into syrup tanks would cause this high pressure gauge needle to balance with pressure in syrup tanks, which would be a false indication of a leak in the high-side circuit.
6. After it has been determined that there are no leaks in the gas circuit, open CO₂ cylinder valve and adjust low pressure regulator to 15 psi. Allow enough time for the syrup tanks to fill completely with gas, (5 minutes or longer).
7. Next, completely back off low-pressure regulator adjusting screw, and if gauge needle of low-pressure regulator commence to move downward, there is leak in the low-pressure circuit. Check all connections with a soap solution, paying particular attention to syrup tank covers. If low pressure gauge needle remains stationary, there is no leak.

CHAPTER V

SERVICE AND MAINTENANCE

This chapter describes service and maintenance procedures to be performed on LIL FELLA MID SIZE JUICE systems and related components.

PERIODIC INSPECTION AND CLEANING

Daily:

1. Clean any storage tanks/B.I.B. racks, connecting sockets/Q.C.D.'s and general storage area with warm water.
2. Check the CO₂ gas supply. If cylinder pressure is below 500 P.S.I., replace the cylinder.
NOTE: Readings should be taken at normal room temperature, approximately 70 degrees "F" and above. If CO₂ cylinder is stored in a walk-in refrigerator, the P.S.I. indicator will read below 500 psi even when cylinder is full.
3. Check the CO₂ gas pressure supplying cooled beverage. These pressures should not change. If a change occurs repeatedly, contact your local service agency. It is suggested to make a comment about this occurrence in NOTE SECTION of manual.
4. Clean the beverage dispensing area.
5. Remove and clean nozzles and all exposed areas on valves.
6. Wipe exterior of unit with moist towel. Stainless cleans well with carbonated water.

Weekly:

1. Order syrup to maintain product inventory.
2. Check all CO₂ gas connections for leaks.
3. Check condenser coil for obstructions or dirt.

Monthly:

1. Clean condenser fins or filter to make sure the refrigeration unit has adequate air flow.
2. Inspect components of cooling unit water bath for cleanliness.
4. Check entire system for leaks or damaged components. Repair as necessary.

PERIODIC CLEANING

Periodically wash all external surfaces of cooling unit, rinse with clean water, then wipe dry with a clean soft cloth.

DO NOT USE ABRASIVE TYPE CLEANERS.

CLEANING CONDENSER COIL

IMPORTANT: Air circulation through the condenser coil required to cool the condenser coil/compressor, is drawn in through grills on cooling unit, through condenser coil and exhausted out grills on the other side of unit. Restricting air circulation through the cooling unit will decrease its cooling capacity.

NOTE: Cleaning condenser coil should be done during non-business hours.

1. Unplug refrigeration unit power cord from electrical socket.
2. Remove 6 screws securing service panels, 2 screws per service panel. Remove panels in preparation for service.
3. Vacuum or use a soft brush to clean fins of condenser coil. Use low-pressure compressed air or CO₂ gas to blow through condenser fins. This should only be performed after normal business hours to prevent dust contamination. A damp cloth on backside of condenser coil will prevent some dust contamination.
4. Plug refrigeration unit power cord in electrical socket.

CHECKING WATER BATH

Periodically check solution level in water bath. If it is low, more solution should be added for maximum product cooling. Before adding more solution, water bath and evaporator should be checked for excessive mineral deposit build up.

1. Unplug refrigeration unit power cord from electrical socket.
2. Lift lid up and off unit.
3. Look down into water bath (use flashlight, if necessary) and inspect water bath, and all components for cleanliness. Water bath and all components should be clear and free of foreign particles.
4. If cleaning of water bath or its components is necessary, do it as outlined in "CHANGING WATER BATH" in this chapter.
5. Fill water bath to top of standpipe, (condensate drain), with water.
6. Install lid.
7. Plug refrigeration unit power cord in proper electrical socket.

CHANGING WATER BATH

NOTE: The water bath should be changed and all components in water bath should be cleaned as often as necessary to keep it clean. A convenient time to perform this operation is when the system is being sanitized.

1. Unplug refrigeration unit power cord from electrical socket.
2. Remove lid from water bath.
3. Look down into water bath (if necessary, use flashlight) and inspect water bath, evaporator and all components for cleanliness. Water, refrigeration evaporator and all components should be clear and free of foreign particles.
4. Pull out standpipe and allow water to drain.
5. Use fiber brush and carefully clean mineral deposit from all components.
6. Wash evaporator coil with a mild soap. Copper cleans well with mild solution of citric acid (1 cup of citric acid for 2 gallons of water). Stainless steel cleans well with carbonated water. Then rinse with clean water.
7. Rinse out water bath with clean water until water running out of drain hose is clean.
8. Install standpipe in drain hose.
9. Fill water bath to top of standpipe, (condensate drain), with water.
10. Install lid.
11. Plug LF-MS-J unit power cord in electrical socket.

HIGH PRESSURE CO2 REGULATOR

The high-pressure CO2 regulator will have two gages that extend above and to the side of the bell housing screw area. The P.S.I. gauge will show graduated indications up to 3000 psi and be the gauge the farthest from the CO2 cylinder connection. This gauge will normally have a Red area indicating 500 psi to 0 psi. This gauge will be used to check volume of liquid in the CO2 cylinder. The other gauge will show regulated pressure that will be delivered to our LF-MS-J. This gauge can be indicated from 0-160 psi up to 0-300 psi. By turning the high-pressure regulator adjustment screw clockwise we will increase pressure supplied to the outlet or the high-pressure regulator.

LOW PRESSURE CO2 REGULATOR

The low-pressure CO2 regulator setting can and will vary dramatically from one installation to the next. Variables such as distance from B.I.B.'s or transfer tanks to point of serving, horizontal or vertical runs, baume of products will influence where the low-pressure regulator is adjusted.

A good starting point as an adjustment is:

40 psi for B.I.B.

and

30 psi for transfer tanks.

NOTE: After primary adjustment on low-pressure regulator always go to farthest serving station from syrup storage area and adjust heaviest baume syrup (normally ORANGE). If an adjustment can be made proceed with all other flavors.

REPLENISHING CO2 SUPPLY

1. Close empty CO2 cylinder shutoff valve.
2. Disconnect high pressure CO2 regulator, then remove empty CO2 cylinder.
3. Install full CO2 cylinder and connect high pressure CO2 regulator. See installation procedure in CHAPTER II.

MAKE SURE CO2 CYLINDER IS POSITIONED IN UPRIGHT POSITION AND FASTENED WITH SAFETY CHAIN. ALWAYS OPEN CO2 VALVE COMPLETELY OR UNTIL BACK SEATED DURING OPERATION. WHEN BOTTLE IS EMPTY ALWAYS CLOSE VALVE ASSEMBLY COMPLETELY.

CLEANING AND SANITIZING

Your local Health Department rules and general area cleanliness should determine the frequency of which the unit should be sanitized.

SANITIZING PROCEDURES

Your local health department rules and general area cleanliness should determine the frequency at which the unit should be sanitized.

EQUIPMENT REQUIRED:

1. Stainless Steel containers (product tanks), or large volume container.
2. CO2 Supply if applicable (Same as used with dispensing unit).
3. Cleaning Agent.
4. Sanitizing Solution.
5. Phenolphthalein.

NOTE: One recommended cleaning agent and sanitizing agent is manufactured by:

MT. HOOD CHEMICAL CORP.
4444 N.W. Yeon Avenue
Portland, Oregon 97210

Trade names are: STAR - CHLORINATED CLEANER
CROWN - 12.5% SODIUM HYPOCHLORITE BLEACH

Use STAR at 18 oz. per 1 gallon of water yields 2% Sodium Hydroxide Solution.

Use Crown at 2 ounce per 9 gallons of water (gives 200 PPM of available chlorine) at a minimum contact time of 10 minutes.

1. Disconnect syrup containers and remove product from tubing by purging with carbon dioxide or flushing with warm water.
2. Visually inspect valve by removing nozzle and inspecting nozzle and valve cavity. Clean nozzle with cleaning agent, then sanitizing solution, then with potable water. Inspect valve cavity and if dirty clean with soft bristle brush. Clean exteriors of valve with a soft cloth and warm water. Replace valve nozzle then go to step #3.
3. Fill syrup lines with a caustic-based (low sudsing, non-perfumed, and rinsed) detergent solution, (STAR). The solution should be prepared in accordance with the manufacturers recommendations, but should be at least 2 percent sodium hydroxide. Make sure the syrup lines are completely filled and allow standing for at least 10 minutes.
4. Flush the detergent solution from the syrup lines with clean water. Continue rinsing until testing with phenolphthalein shows that the rinse water is free of residual detergent.
5. Fill the syrup lines with a low PH (7.0) chloride solution containing maximum 200-PPM chlorine. Make sure that lines are completely filled and allow standing for 30 minutes.
6. Reconnect syrup containers and ready Unit for operation.
7. Draw drinks to refill syrup lines and flush the chloride solution from the dispenser.
8. Taste the beverage to verify that there is no off taste.

NOTE: WHEN SANITIZING A TWO FLAVOR VALVE BOTH SYRUPS SHOULD BE FLUSHED SIMULTANEOUSLY, BOTH SYRUPS SHOULD BE CLEANED, (DETERGENT SOLUTION), SIMULTANEOUSLY, BOTH SYRUPS SHOULD BE FLUSHED UNTIL FREE OF DETERGENT SIMULTANEOUSLY AND BOTH SYRUPS SHOULD BE SANITIZED SIMULTANEOUSLY.

BRIX INSTRUCTIONS

1. Make sure carbonator/water flow is in an operating condition, i.e., high-pressure regulators set, water and power on and refrigeration in a ready to go mode. In the case of juice systems make sure water flow is un-restricted. It is also recommended that a water pressure regulator be utilized on all systems. Water bath systems must have an ice bank formed.
2. Adjust water flow to 6 ounces in 5 seconds.
3. Remove nozzle (twist and pull down), then insert syrup separator through nozzle, be it "S" type or plastic tube, and on ¼" plastic syrup outlet located inside hidden nozzle area. Then press nozzle back in position.
4. Actuate valve until syrup separator is full of syrup. Hold brix cup close enough to valve outlet to form "S" on the flexible plastic tube so as to prevent any water following the flexible tube into syrup section. This formed "S" will also hold syrup in tube for a more reliable brix reading.
5. Actuate valve allowing the soda water to flow into large section of cup and syrup into smaller section. Adjust the syrup metering pin/flow-control as necessary to secure a proper brix. When proper brix syrup adjustments have been made, the two sections of the cup should fill to the desired ration.

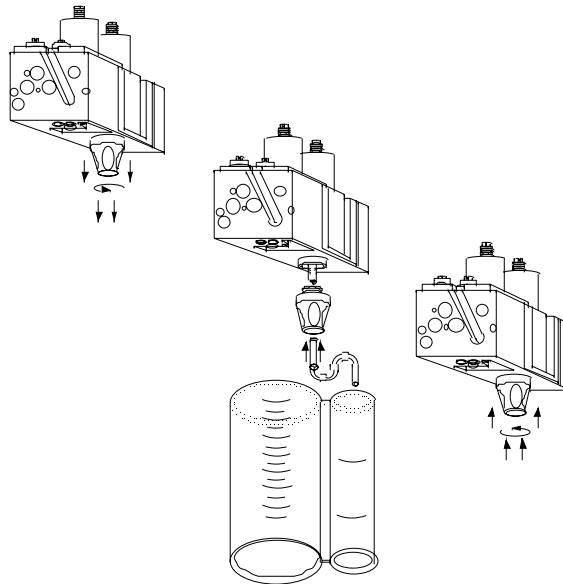

Brix Instructions Continued

BRIXING PFC-II VALVE

The water and syrup flows are individually adjusted by their respective metering pin or flow-controls. Located under the valve cover on the top rear of the valve, see illustration.

One recommended method utilizes the ratio brix cup. The brix cup is divided into two sections, one to hold up to 9 parts water and the smaller section to hold one or two parts of syrup. When adjusting a flavor with a ratio of more than 9 to 1 syrup 2 line must be used. When using syrup 2 line the waterside is doubled to 18 to 1 vs. 9 to 1.

When facing the valve, the syrup is always to the right and the water/soda is to the left. To decrease syrup or water flow, turn metering pin clockwise. To decrease syrup or water flow, when using flow control valves turn counter-clockwise. To increase, reverse rotation respectively. The ultimate goal is to achieve a proper ratio of water vs. syrup. This ratio can and will vary with differing products.

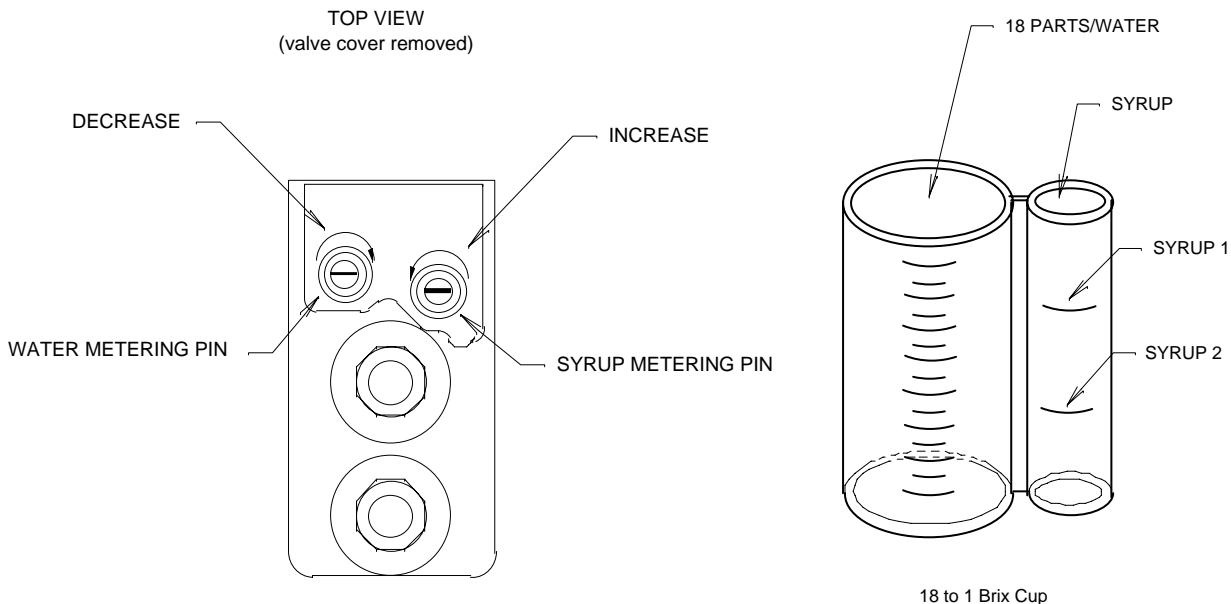

Maintenance:

Cleaning your valve is recommended to insure a constant quality drink. If a valve is not sanitized on a regular basis (nightly recommended), the possibility of foamy and off-tasting drinks is greatly increased.

1. Turn off key switch normally located on valve plate or side of cabinet. Or disconnect tower from electrical supply.
2. Clean all exposed areas of valve with mild soap or sanitizing solution and warm water.
3. Remove nozzle and place in warm water. Do not soak nozzle in bleach water, this will turn the nozzle yellow and cause deterioration. It is recommended to use a soft bristle brush, part No. S-1064, to clean any hard to get areas of valve or nozzle. Do not soak nozzle in extremely hot water, nozzle will warp.

TROUBLE SHOOTING

IMPORTANT: Only qualified personnel should service LF-MS-J unit and components.

WARNING: To avoid personal injury and or property damage, always disconnect electrical power, shut off plain water and CO2 supplies before starting any repairs. If repairs are to be made to the water system, bleed water system pressure before proceeding. If repairs are to be made to syrup system, remove quick-disconnects from syrup tanks, or remove OCD from BIB, then bleed system pressure before proceeding.

COOLING UNIT

Trouble		Probable Cause		Remedy
Frozen water bath	1. 2. 3.	Bad ice bank control. Agitator pump defective Under charge on refrigerant.	1. 2. 3.	Replace bad ice bank control. Replace Agitator pump. Find refrigerant leak, repair and recharge.
Cooling or condensing unit non-operational	1. 2. 3. 4. 5. 6. 7. 8.	No electrical power. Defective ice bank control. Dirty water bath. Dirty condenser unit. Improper voltage/amperage Loss of refrigerant. Bad overload and relay. Compressor bad. Restriction (pinched or crimped line).	1. 2. 3. 4. 5. 6. 7. 8.	Plug power cord into electrical box. Check on/off switch. Replace ice bank control. Change water bath. Clean condenser unit w/vacuum cleaner. Check for proper voltage/amperage. Repair leak and replenish refrigerant. Replace overload and relay Replace compressor. Repair, straighten or replace defective line.

Compressor does not operate	<ol style="list-style-type: none"> 1. 2. 3. 4. 5. 6. 7. 8. 	<ol style="list-style-type: none"> 1. No power source. 2. Electrical power to cooling unit turned off. 3. Low voltage. 4. Loose, disconnected, or broken wire. 5. Inoperative ice bank control. 6. Inoperative overload protector or start relay. 7. Inoperative compressor. 8. Full ice bank. 	<ol style="list-style-type: none"> 1. 2. 3. 4. 5. 6. 7. 8. 	<ol style="list-style-type: none"> 1. Plug power cord to electrical box. Check line voltage. 2. Turn on power switch to unit. 3. Voltage must be at least 110 V at compressor terminals at start. 4. Tighten connection or replace broken wiring. 5. Replace ice bank control. 6. Replace defective part. 7. Replace compressor. 8. Refrigeration not called for.
Compressor works continuously but does not form ice bank.	<ol style="list-style-type: none"> 1. 2. 3. 4. 5. 	<ol style="list-style-type: none"> 1. Cooling capacity is exceeded by over drawing. 2. Cooling unit located in excessively hot area. 3. Air circulation through condenser coil is restricted 4. Loss of refrigerant or insufficient charge. 5. Dirty water bath. 	<ol style="list-style-type: none"> 1. 2. 3. 4. 5. 	<ol style="list-style-type: none"> 1. Reduce amount of drinks taken per given time of install higher volume unit. 2. Relocate cooling unit. 3. Check and if necessary, clean condenser coil. 4. Repair leak and/or recharge with sufficient refrigerant. 5. Clean water bath.
Compressor will not stop after forming ice bank	<ol style="list-style-type: none"> 1. 2. 	<ol style="list-style-type: none"> 1. Ice bank control capillary tube kinked or broken. 2. Ice bank control stuck in closed position. 	<ol style="list-style-type: none"> 1. 2. 	<ol style="list-style-type: none"> 1. Replace ice bank control. 2. Replace ice bank control.
<p>Note: During overload protector shut off condenser fan motor will continue to work. Otherwise, troubleshooting condenser fan motor problems is the same as "Compressor does not operate", paragraph in addition to the following.</p>				
Condenser fan motor not operating	<ol style="list-style-type: none"> 1. 2. 3. 	<ol style="list-style-type: none"> 1. Electrical cord loose or disconnected from condenser fan motor or compressor terminals. 2. Fan blade obstructed. 3. Inoperative condenser fan motor. 	<ol style="list-style-type: none"> 1. 2. 3. 	<ol style="list-style-type: none"> 1. Tighten connections or replace cord. 2. Remove obstruction. 3. Replace condenser fan motor.

DISPENSING VALVES

<p>Water or syrup leaking from nozzle after actuation</p>	<p>1.</p>	<p>Foreign debris under plunger seat or bent, creased stem.</p>	<p>1.</p>	<p>a. Disconnect syrup or water from affected valve. b. Relieve pressure by activating valve. c. Remove E-623 nut from syrup or water solenoid. d. Remove e-525 coil assembly from e-527 stem. e. Remove E-527 stem from valve body. Note: care should be taken not to dent smooth E-527 wall. f. Valve stem seat should be inspected for any foreign debris. If debris is found remove at this time, also check E-730 stem. Movement should be unrestricted and free. g. Inspect E-730 plunger seat for damage, replace if damaged. h. Reassemble by reversing above procedure.</p>
<p>No water, no syrup being dispensed from valve</p>	<p>1. 2. 3. 4. 5. 6.</p>	<p>No electrical power. Frozen water bath. Pinched or crimped lines. Broken sub-miniature switch. Bad transformer. Disconnected wire.</p>	<p>1. 2. 3. 4. 5. 6.</p>	<p>Plug power cord into electrical box. Check line voltage. See "Frozen water bath". Repair defective line. Replace defective switch. Replace defective transformer. Attach disconnected wire.</p>

No syrup being dispensed	<ol style="list-style-type: none"> 1. 2. 3. 4. 5. 6. 7. 8. 	<p>Syrup container empty.</p> <p>Syrup lines crimped.</p> <p>CO2 cylinder empty.</p> <p>QCD of syrup installed incorrectly.</p> <p>Low pressure regulator defective or plugged.</p> <p>Syrup disconnect not attached correctly.</p> <p>Loose electrical connection of syrup solenoid and or open electrical connection.</p> <p>Frozen water bath.</p>	<ol style="list-style-type: none"> 1. 2. 3. 4. 5. 6. 7. 8. 	<p>Replenish syrup supply.</p> <p>Straighten syrup lines.</p> <p>Change CO2 cylinder.</p> <p>Re-install QCD correctly.</p> <p>Repair or replace low-pressure regulator.</p> <p>Lubricate and attach.</p> <p>Tighten connection and/or repair open circuit. Check proper voltage.</p> <p>See "Frozen Water Bath".</p>
No water being dispensed	<ol style="list-style-type: none"> 1. 2. 3. 4. 5. 6. 7. 	<p>Plain water inlet supply shutoff closed.</p> <p>Water filter fouled/clogged.</p> <p>Pinched or crimped line.</p> <p>Loose electrical connection, 24 volt.</p> <p>Water pump motor worn out or damaged.</p> <p>Water pump worn out or damaged.</p> <p>Frozen water bath.</p>	<ol style="list-style-type: none"> 1. 2. 3. 4. 5. 6. 7. 	<p>Open plain water inlet supply line shut off valve.</p> <p>Replace filter or cartridge.</p> <p>Repair defective line.</p> <p>Tighten connection and or repair open circuit.</p> <p>Replace motor.</p> <p>Replace water pump.</p> <p>See "Frozen water bath".</p>
Water-to-syrup ratio to low or too high	<ol style="list-style-type: none"> 1. 2. 3. 	<p>Syrup flow regulator not properly adjusted.</p> <p>CO2 gas pressure in syrup tanks insufficient.</p> <p>Syrup tubing I.D. insufficient.</p>	<ol style="list-style-type: none"> 1. 2. 3. 	<p>Adjust water-to-syrup ratio (see dispensing station installation instructions).</p> <p>Adjust low-pressure regulator as instructed.</p> <p>Increase syrup tubing I.D. Note: see "Brix instructions"</p>
Adjustment of syrup metering pin does not produce desired water-to-syrup ratio	<ol style="list-style-type: none"> 1. 2. 3. 4. 5. 6. 	<p>No syrup supply.</p> <p>Syrup tank quick disconnects not secure.</p> <p>Low pressure CO2 regulator out of adjustment.</p> <p>B.I.B. QCD disconnected or improperly installed.</p> <p>Syrup line restricted.</p> <p>Dirty or inoperative metering pin or piston in syrup flow control.</p>	<ol style="list-style-type: none"> 1. 2. 3. 4. 5. 6. 	<p>Replenish syrup supply as instructed.</p> <p>Secure quick disconnects.</p> <p>Adjust low pressure CO2 regulator as instructed.</p> <p>Connect B.I.B. disconnect securely.</p> <p>Clear restriction or replace restricted line.</p> <p>Disassemble and clean syrup flow control. Adjust water-to-syrup ratio, see "Brix instruction".</p>

